

YALE GP-EB Series

This series of pneumatic tire lift trucks are available in diesel power. The GP-EB series offers superior traction, gradeability, and drawbar pull on paved, gravel, and unimproved surfaces. The EB Series has high under-clearance, productive travel/lift speeds and excellent maneuverability to meet the demands of tough applications [lumber, pipe, pre-stressed concrete, block/brick and heavy cargo].

Various attachments may be required for above applications.

ERGOCAB™

Yale's ERGOCAB™ is ergonomically designed for maximum operator productivity.

Cab features ■ full-length handrails ■ three step entry on special floorboards ■ open floor with low front dash ■ all gauges, switches, key start and park brake to right of driver ■ two way adjustable steering column for height and tilt angle ■ inch brake/brake/accelerator pedal arrangement ■ custom molded floor mat ■ under cab sound insulation ■ angled overhead guard bars ■ adjustable right hand armrest and right hand directional shift controller ■ wide angle side view mirrors ■ red warning light on steering column ■ an LCD message center ■ small lever actuator for hydraulic functions ■ a full suspension vinyl seat ■ dual horn locations

Enclosed cab option features ■ curved tempered front and rear glass ■ twin blade front wipers, rear wiper and top wiper with washer fluid spray ■ ten high capacity outlet vents for heating ■ cab filter for all incoming air ■ front and rear screen demisting ■ top cover laminated glass ■ coat hook ■ storage bins

The entire cab tilts for complete service access to major powertrain components

Diesel Engine Specifications

Engine: Perkins 1006-6T
Cylinder: 6
Displacement: 6 liter, 365 cu in
Torque: 464 @ 1400 RPM
Horsepower: 142 @ 2200 RPM

Perkins 1006-6T

The engine features a direct fuel injection with *fast ram combustion* for improved fuel efficiency/power and reduced exhaust emissions. The throttle and governor in the fuel injection pump controls the quantity of fuel sent to the injectors.

The cast iron block and cylinder heads have a swirl combustion chamber design which combine for high power and fuel efficiency. There are 5 main bearings for the crankshaft. A Cummins 5.9L 6 cylinder turbo-charged diesel engine is optional.

Exhaust

The vertical exhaust is standard and has a large capacity cylindrical muffler.

Air Cleaner

A two-stage air cleaner mounted inside the engine compartment with outside air intake and rain cap. Optional exhaust aspirated air cleaner with a high air intake for extremely dusty environments.

Cooling system

The cooling system utilizes a 15 psi cooling system, pusher fan, fan shroud and a corrugated fin radiator for maximum cooling efficiency.

The Perkins diesel engine uses a five blade fan which is belt driven off the crankshaft.

Drive Axle

The planetary drive axle with secure pinion retention is made of ductile iron and is bolted to the frame. The drive shafts are fully floating allowing the truck and load weight to be carried by the axle housings.

Transmission

The Yale three-speed powershift transmission has constant mesh gearing and a high ratio torque converter to multiply engine torque and cushion the drive train (Auto-shift transmission option). Hydraulic multiple disc clutch packs assures smooth direction, range selec-

tion and long life. It has individual pedals for inching and braking. The external control valve is easy to service. A neutral start switch is standard. An optional Foot Directional Control (FDC) provides direction change in lieu of column shifter.

Hydraulic System

The tandem hydraulic pumps operate at 3000 PSI. All hydraulic fittings include flat face O-ring seals. Small hydraulic lines and components allow for easy maintenance access. Electro mechanical solenoids allow precise control of oil flow during hoist and tilt functions and provide excellent load control.

Hydrostatic Steering

The hydrostatic system requires no mechanical drag link steering connections and components. Steering is actuated with a steer pump that controls a two way cylinder bolted to the steer axle with eight bolts. The steer axle frame is made of high strength ductile cast steel. The adjustment free tie rods are made of T-1 steel. Tapered roller bearings are use with the heavy-duty spindles. Load sensing steering provides optimum performance at all engine speeds.

Chassis

A rugged unitized frame structure is designed for tough, demanding applications with a

(continued on back page)

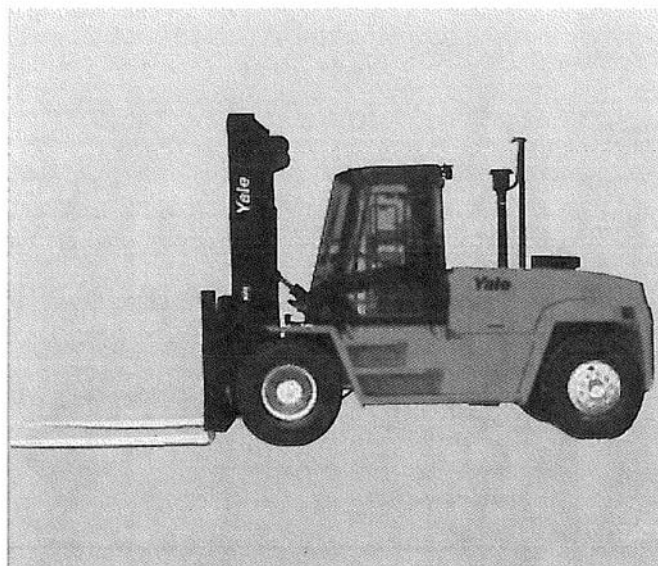

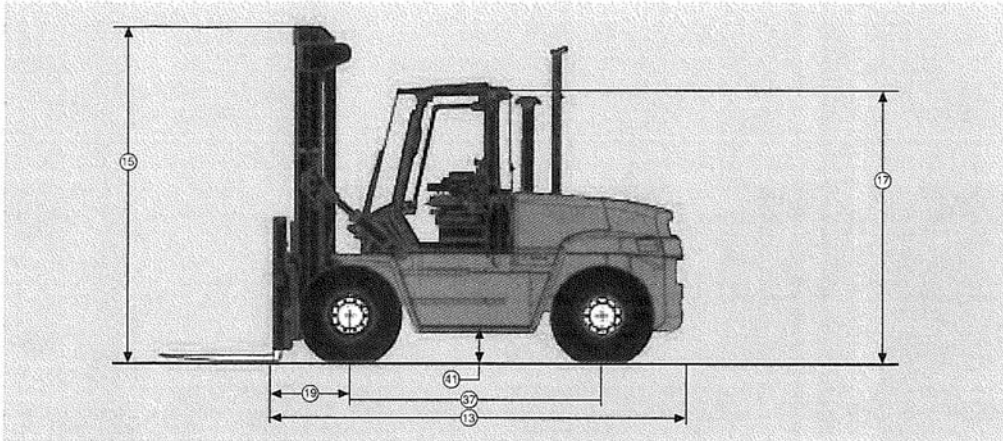

GENERAL	1	Manufacturer	Manufacturer's Name	YALE	
	2	Model Designation	Manufacturer's Designation	GDP300EB	
	3	Load Capacity	Rated capacity	Perkins	Cummins
Wheels	4	Load Center	Distance	30000 (13600)	
	5	Power Type	Battery, Diesel, LPG, Electric	Diesel-Turbo	
	6	Operation	Manual, Pedestrian, Stand, Sit, Seat	Sit	
	7	Tire Type	C-Cushion, P-Pneumatic, Front/Rear	P/P	
	8	Wheels	Number Front/Rear (X = Driven)	4X/2	
	9	Lift Height		212.5 (5400)	
	10	Free Lift		0	
	11	Fork	Dimensions	3.5 x 8 x 72 (89 x 203 x 1830)	
	12	Mast Tilt	Forward/Backward	degree 15/12	
	Dimensions	13	Length	To Face of Forks	in. (mm) 196.6 (4994)
14		Overall Width		in. (mm) 103.03 (2617)	
15		Height of Mast	Lowered	in. (mm) 175.8 (4465)	
16			Extended without LBE	in. (mm) 280.3 (7120)	
17		Overhead Guard	Height	in. (mm) 119.8 (3043)	
18		Turning Radius	Outside	in. (mm) 180.3 (4580)	
19		Load Length	Front Overhang	in. (mm) 33.31 (847)	
20		Aisle Width	RT. Angle Slack (Add length of load)	in. (mm) 221.5 (5626)	
21				in. (mm) ---	
Performance		22	Towing Coupling	Pin Height	in. (mm) 26.1
	23	Travel Speed	With/Without Load	mph (kph) 16.5 (26.6)/17.5 (28.2) 17.9 (28.8)/19.0 (30.6)	
	24	Lifting Speed	With/Without Load	fpm (m/s) 58 (.29)/87 (.44) 63 (.32)/95 (.48)	
	25	Lowering Speed	With/Without Load	fpm (m/s) 98 (.50)/87 (.44) 92 (.47)/82 (.42)	
	26	Drawbar Pull	With/Without Load (Perkins)	lb. (kg) 21486 (9746)/13719 (6223)	
	27	Drawbar Pull	With/Without Load (Cummins)	lb. (kg) 24191 (10973)/13719 (6223)	
	28	Gradeability at 1mph	With/Without Load	% 36/40 40/40	
	29	Maximum Gradeability	With/Without Load	% 43/40 50/40	
	30	Maximum Drawbar Pull	With/Without Load (Perkins)	lb. (kg) 26080 (11830)/13719 (6223)	
	31	Maximum Drawbar Pull	With/Without Load (Cummins)	lb. (kg) 29366 (13820)/13179 (5978)	
WEIGHTS	32	Working Pressure	For Attachments	psi 2400	
	33	Oil Flow	For Attachments	gpm 24.7	
	34	Unloaded Weight		lb. (kg) 36753 (16671)	
	35	Axle Loading	With Load, Front/Rear	lb. (kg) 62022 (28133)/4731 (2146)	
	36		Without Load, Front/Rear	18769/17964	
	37	Tire Size	Front	12.00-20 20PR	
	38		Rear	12.00-20 20PR	
	39	Wheelbase		in. (mm) 129.9 (3300)	
	40	Tread Width	Front	in. (mm) 89.6 (2276)	
	41		Rear	in. (mm) 78.74 (2001)	
ENGINE	42	Ground Clearance	Under Mast, With Load	in. (mm) 8.12 (206)	
	43		Center of Wheelbase, With Load	in. (mm) 12.8 (329)	
	44	Service Brake	Method of Operation/Control	Foot/Air	
	45	Parking Brake		Hand/Mechanical	
	46	Engine	Manufacturer/Type	1006-6T 6BT5.9-C152	
MOTORS	47		Output, In Accordance with ISO 1585	hp (kw) 144 (108) 152 (113.3)	
	48		Number of Cylinders/Displacement	No. (cc) 6 (366) 6 (359)	
	49	Transmission	Type	Powershift	
	50	Noise Level	LEQ	db(A) 77	
	51	Hydraulic Tank	Capacity	gal. (litre) 24.6 (93)	
	Fuel Tank	Capacity	gal. (litre) 32 (122)		
	Drive Control		Torque Converter		

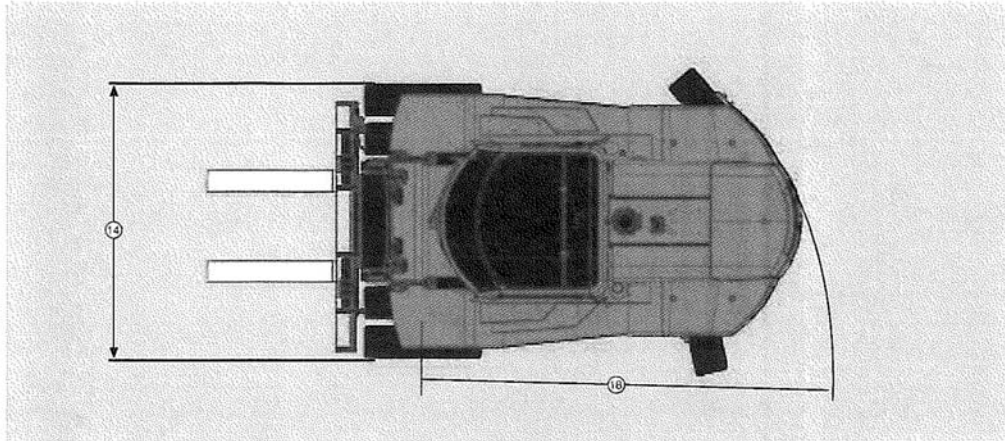

	YALE		YALE		
	GDP330EB		GDP360EB		
GENERAL	1	Perkins	Cummins	Perkins	Cummins
	2	33000 (15000)		36000 (16400)	
	3	24 (600)		24 (600)	
	4	Diesel-Turbo		Diesel-Turbo	
	5	Sit		Sit	
Wheels	6	P/P		P/P	
	7	4X/2		4X/2	
	8	212.5 (5400)		212.5 (5400)	
	9	0		0	
	10	3.5 x 8 x 72 (89 x 203 x 1830)		3.5 x 8 x 72 (89 x 203 x 1830)	
Dimensions	11	15/12		15/12	
	12	196.6 (4994)		201.3 (5113)	
	13	103.03 (2617)		103.03 (2617)	
	14	175.8 (4465)		175.8 (4465)	
	15	280.3 (7120)		280.3 (7120)	
	16	121.7 (3091)		121.7 (3091)	
	17	180.3 (4580)		184.5 (4687)	
	18	33.31 (847)		33.31 (847)	
	19	221.5 (5626)		273.7	
	20	---		---	
Performance	21	26.93		26.93	
	22	16.1 (25.9)/17.8 (28.6)	17.5 (28.2)/19.4 (31.2)	16.0 (25.7)/17.8 (28.6)	17.4 (28)/19.4 (31.2)
	23	58 (.29)/87 (.44)	63 (.32)/95 (.48)	58 (.29)/87 (.44)	63 (.32)/95 (.48)
	24	98 (.50)/87 (.44)	92 (.47)/82 (.42)	98 (.50)/87 (.44)	92 (.47)/82 (.42)
	25	21160 (9598)/14340 (6505)		21160 (9598)/14043 (6370)	
	26	220121 (9127)/14340 (6505)		20036 (9088)/14043 (6370)	
	27	33/39	33/39	30/36	30/36
	28	38/39	38/39	34/36	34/36
	29	24960 (13445)/14340 (6505)		24850 (11272)/14043 (6370)	
	30	24486 (11107)/14340 (6505)		24400 (11068)/14043 (6370)	
WEIGHTS	31	2400		2400	
	32	24.7		24.7	
	33	39303 (17828)		41253 (18712)	
	34	67232 (30496)/5071 (2301)		71125 (32282)/6128 (2780)	
	35	19675/19628		19245/22008	
	36	12.00-20 20PR		12.00-20 20PR	
	37	12.00-20 20PR		12.00-20 20PR	
	38	129.9 (3300)		129.9 (3300)	
	39	89.6 (2276)		89.6 (2276)	
	40	78.74 (2001)		78.74 (2001)	
ENGINE	41	8.94 (227)		8.94 (227)	
	42	13.6 (346)		13.6 (346)	
	43	Foot/Air		Foot/Air	
	44	Hand/Mechanical		Hand/Mechanical	
	45	1006-6T	6BT5.9-C152	1006-6T	6BT5.9-C152
	46	144 (108)	152 (113.3)	144 (108)	152 (113.3)
MOTORS	47	6 (366)	6 (359)	6 (366)	6 (359)
	48	Powershift		Powershift	
	49	77		77	
	50	24.6 (93)		24.6 (93)	
	51	32 (122)		32 (122)	
	Torque Converter		Torque Converter		

low step height for easy entry and exit. Side plates are 1/2" (20mm) thick. Mast is mounted to the frame not the drive axle.

Masts

Yale Hi-Vis Simplex and Triplex masts afford operators outstanding visibility. Nested channel design incorporates full-face load rollers for durability. Rolled mast channels and formed cross-members provide high strength. Leaf-type chain provides superior strength.

Carriage

The standard carriage is a pin type, 98.5" wide. Fork spacing ranges from 2.4" inside to inside, 89.4" outside to outside with a 2.95" diameter fork pin. The carriage is equipped with 6 angled load rollers.

Brakes

The brakes are "S-cam" power-assisted air type. A separate air compressor air filter provides filtration for the brake system under all operating conditions.

An optional wet disc brake axle with dry disc park brake is optional.

Truck performance may be affected by the condition of the vehicle, how it is equipped and the application. Consult your Yale dealer if any of the information shown is critical to your application. Specifications are subject to change without notice.

This truck meets all design specifications of ANSI B56.1 Safety Standard for Powered Industrial Trucks at the time of manufacture. Classified by Underwriters' Laboratories, Inc. as to fire hazard only for type E and EE (optional) industrial trucks.

Standard Lift Specifications

(For other available mast heights-contact your local Yale Dealer)

Model	O.A.H. in. (mm)	Free Fork Ht. in. (mm)	Max. Fork Ht. in. (mm)	Tilt Rwd-Fwd	Drive Tire Size	O.A.W. in. (mm)
GDP300EB Simplex	143 (3630)	0	147.5 (3750)	15 (12)	11.0x20.0	102.1
	161 (4095)	0	183 (4650)	15 (12)	11.0x20.0	102.1
	176 (4470)	0	212.5 (5400)	15 (12)	11.0x20.0	102.1
	191.5 (4865)	0	244 (6200)	15 (12)	11.0x20.0	102.1
GDP330/360EB Simplex	143 (3630)	0	147.5 (3750)	15 (12)	12.0x20.0	103
	161 (4090)	0	183 (4650)	15 (12)	12.0x20.0	103
	176 (4470)	0	212.5 (5400)	15 (12)	12.0x20.0	103
	191.5 (4865)	0	244 (6200)	15 (12)	12.0x20.0	103

Lift and Lower Speeds ft/min (m/s), Weights

Model	Lift Speed Diesel Empty/Loaded	Lower Speed Diesel Empty/Loaded	*Weights
GDP300EB ft/min mm/sec.	63/58 .32/.29	87/98 .44/.50	36,753 lbs. 16,671 kg.
	63/58 .32/.29	87/98 .44/.50	39,303 lbs. 17,828 kg.
GDP360EB ft/min mm/sec.	65/50 .33/.25	66/51 .34/.26	41,235 lbs. 18,720 kg.

Mast Dimensions

Model	Maximum Fork Height in (mm)	Overall Lowered Height in (mm)	Overall Extended Height in (mm)
GDP300/330/360EB Simplex	147.5 (3750)	143.5 (3625)	215.5 (5470)
	183.0 (4650)	161.0 (4090)	251.0 (6370)
	212.5 (5400)	176.0 (4465)	280.5 (7120)
	244.0 (6200)	191.5 (4865)	312.0 (7920)

* Lift heights over 220.5' (6200mm) max. Fork height may require reduced capacity and restricted back tilt.



Manufactured in our own ISO 9002 Registered Facilities

Yale Materials Handling Corporation
P.O. Box 7367, Greenville, NC 27835-7367

Copyright 1999, Yale Materials Handling Corporation

2275-3B 2/02-50
Printed in U.S.A.