

MASTER COPY

# CLARK Crane Division

# 7700 Specifications

*Arthur Travis*

*General*

## 300 Ton Truck Crane

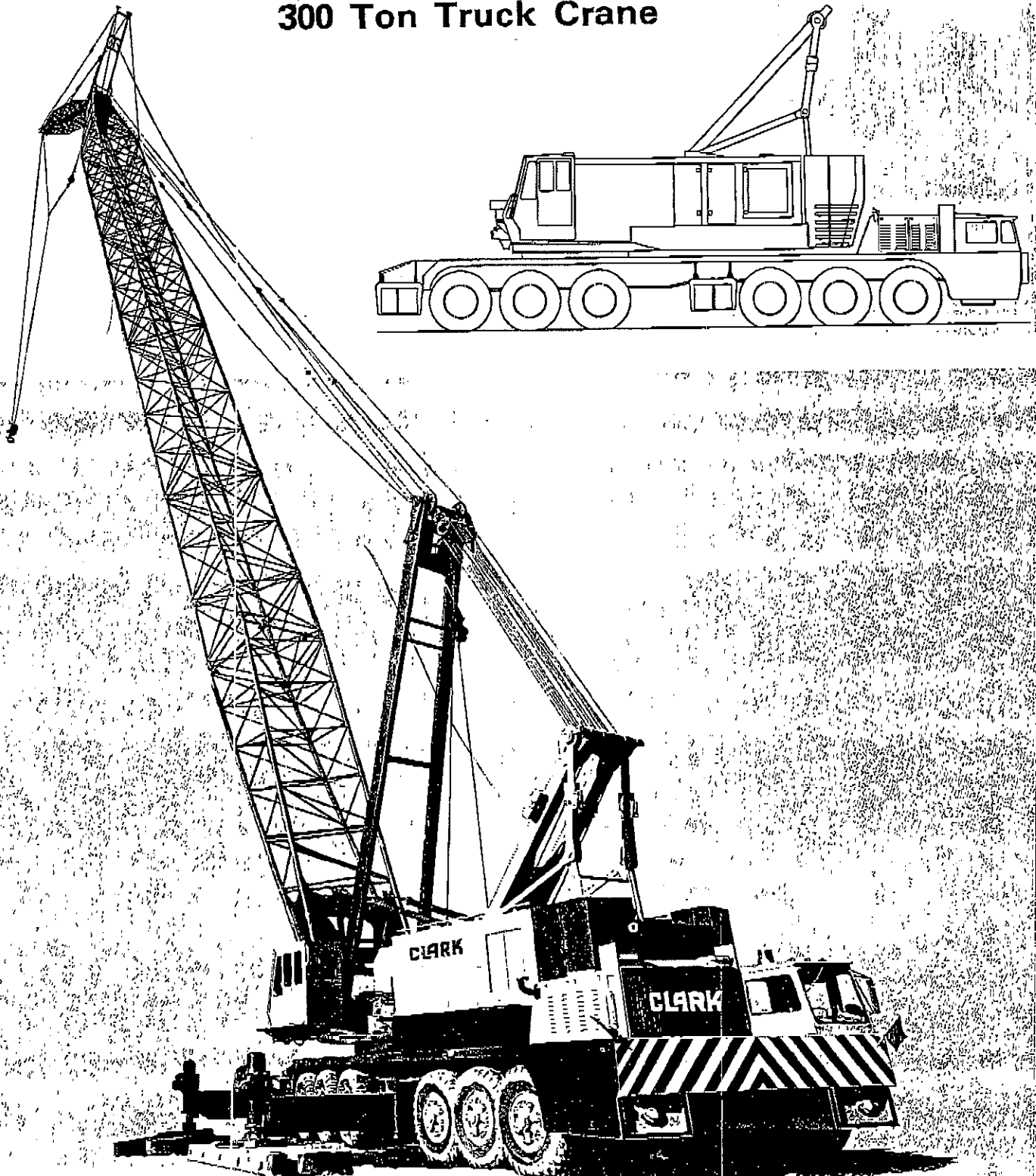

# CLEARANCE & DIMENSIONS

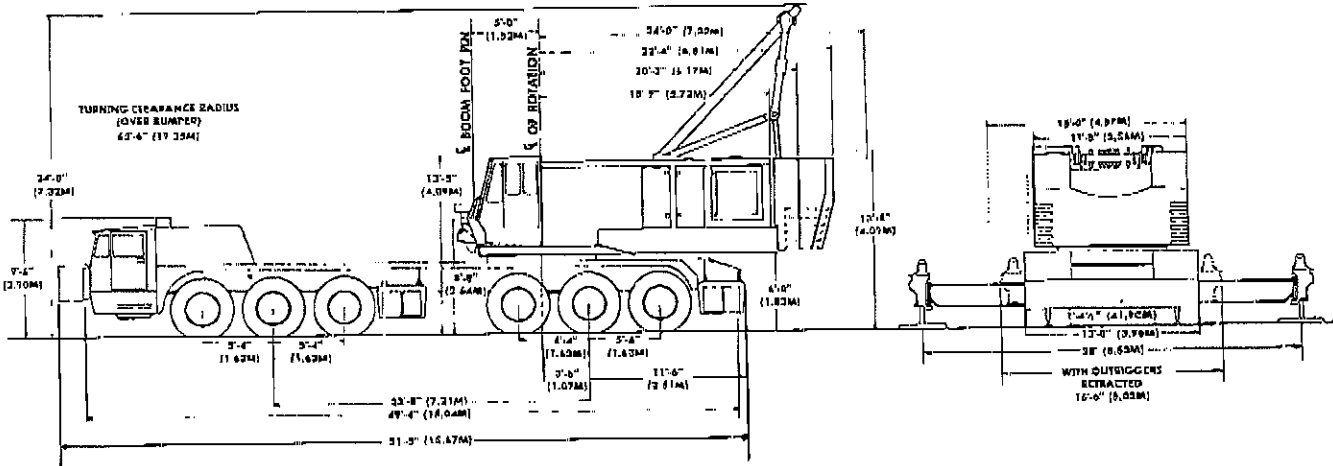

Relative position of the upper works, as shown, is for dimensioning purpose only, and is not recommended for use.

# WEIGHTS OF COMPONENT PARTS

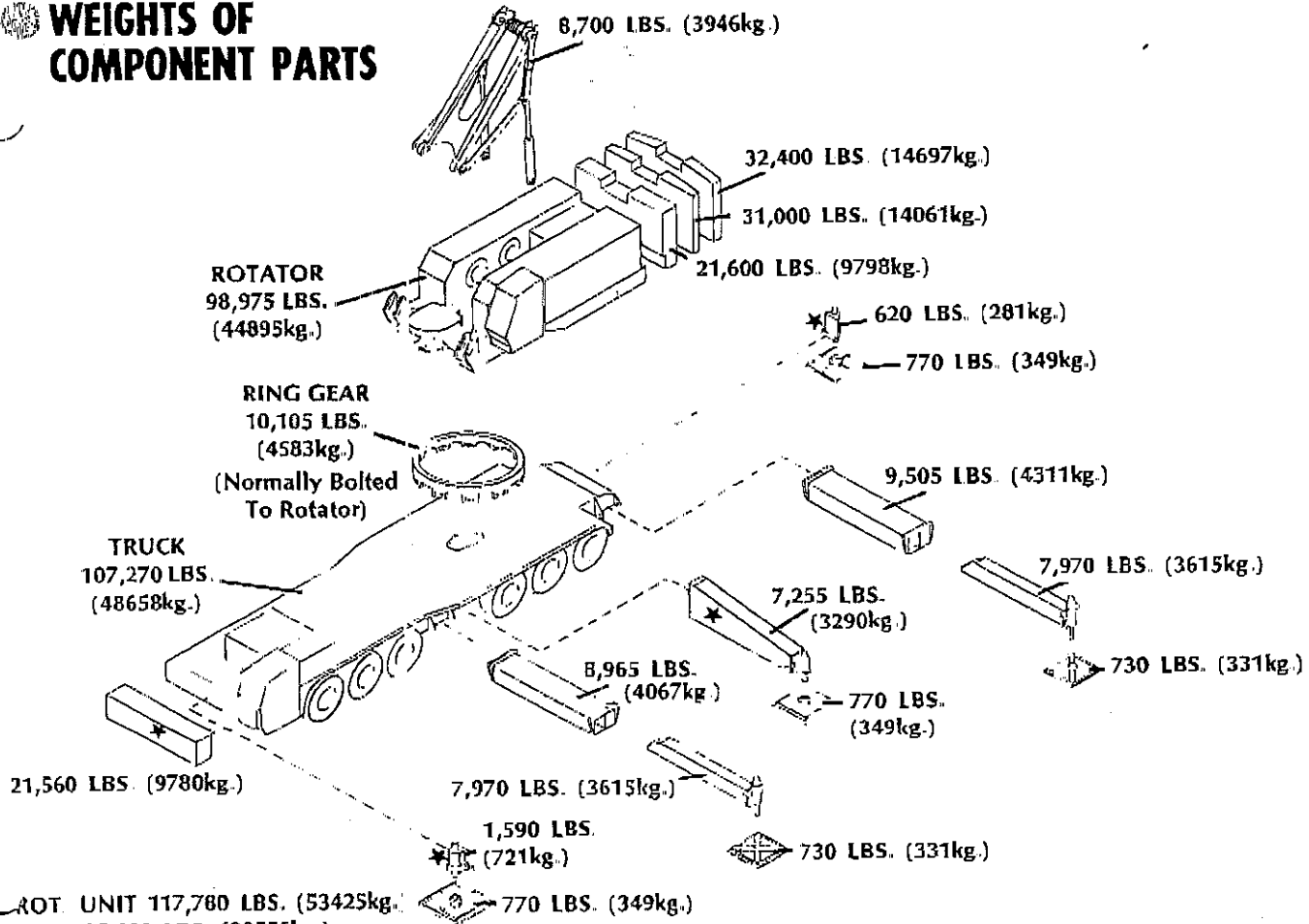

ROT. UNIT 117,780 LBS. (53425kg.)  
CWT. 85,000 LBS. (38556kg.)  
TRUCK 159,160 LBS. (72195kg.)  
★OPTIONAL EQUIP.

R-1

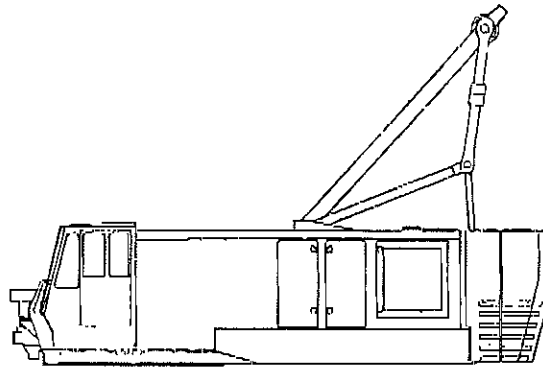

**ROTATING ASSEMBLY**

Equipment includes: Engine (See Item No. RO-100); independent fully hydraulic two drum boom hoist with infinite speed control and power controlled boom lowering; full hydraulic main hoist with infinite speed control in 2 ranges and power controlled lowering on all drums, multi position hydraulically controlled environmental pod; full hydraulic swing system; roller bearing swing circle; cab shutters; counterweight 85,000# (38 556kg); hydraulically controlled backhitch gantry; positive swing lock; running boards with handrails; signal horn; air and electric control equipment.

202,780 LBS. (91981kg)

T-1

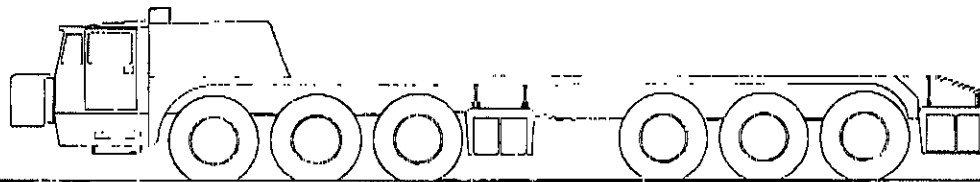

**TRUCK MOUNTING**

Equipment includes: LIMA truck with 12 x 6 drive; engine (See Item No. TO-35); 16:00" x 25" (40 6cm x 63 5cm) - 24 ply rating tires; 6 speed powershift transmission with electric controls, torque converter and hydraulic retarder; 3 planetary driving axles and inter-axle differential; 3 steering axles with power steering; pin on type outrigger boxes; hydraulic outriggers; air service brakes on all wheels; full width and length deck; fenders; flaps; mast rest; half cab; instruments; controls; directional signals; backup lights; west coast mirrors; and tools

160,540 LBS. (72821kg)

A-2

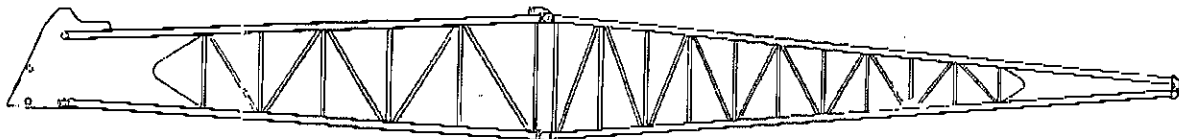

**CRANE ATTACHMENT**

Equipment includes: 70' (21.34M) pin connected tubular boom [90' (228 6cm) x 108" (274 3cm)] [40' (12.19M) base and 30' (9.14M) heavy duty point section] with 7 sheaves for 15 part reeving; rope guards; mast with 14 part boom hoist reeving; swaged type pendants for basic boom; 38' (96.52cm) front and 38" (96.52cm) rear hoist drums; and telescopic boomstops with electric over air shutoff.

31,365 LBS. (14227kg)

Note: Maximum boom length with heavy duty point section, 250' (76.20M)  
 Maximum boom length with light duty point section, 330' (100.58M).  
 See capacity chart for ratings on light and heavy duty boom points

Relative position of the upper works, as shown, is for dimensioning purpose only, and is not recommended for use

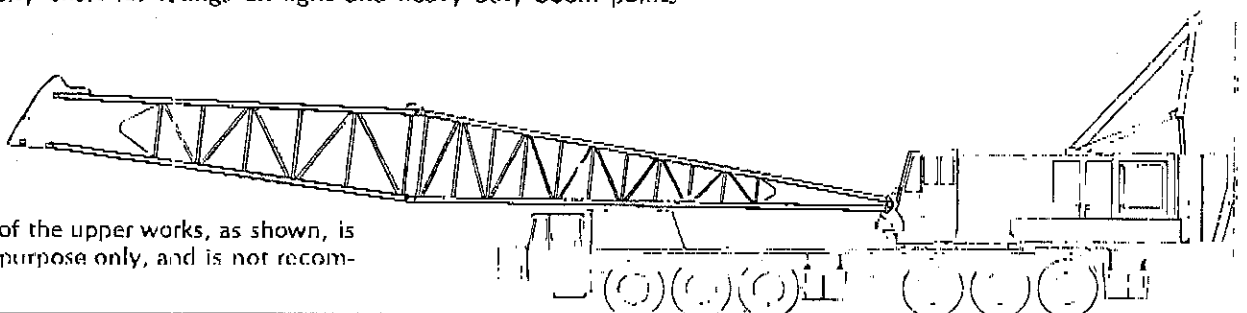

TOTAL WEIGHT OF R-1, T-1 & A-2 = 394,685 LBS. (179 029Kg)  
 TOTAL WEIGHT OF R-1 & T-1 = 363,320 LBS. (164 802Kg)

31567

## AXLE LOADING AND WEIGHTS

Complete Machine Equipped As Follows: Carrier, Outrigger Boxes, Outrigger Beams, Floats, Rotating Unit, Main Counterweight, and 70' (21.34M) Basic Boom.

Weight Combinations	Boom Position	Front Bogie	Rear Bogie	Total Weight
	F	*	*	*
Complete Machine 1	R	146,285 Lbs. (66355kg.)	248,400 Lbs. (112674kg.)	394,685 Lbs. (179029kg.)
Machine Less Main Counterweight 2	F	90,895 Lbs. (41230kg.)	218,790 Lbs. (99243kg.)	309,685 Lbs. (140473kg.)
	R	61,380 Lbs. (27842kg.)	248,305 Lbs. (112631kg.)	309,685 Lbs. (140473kg.)
Machine Less Main Counterweight, Boxes, Beams, and Floats 4	F	86,670 Lbs. (39314kg.)	169,745 Lbs. (76996kg.)	256,415 Lbs. (116310kg.)
	R	57,155 Lbs. (25926kg.)	199,260 Lbs. (90384kg.)	256,415 Lbs. (116310kg.)
Machine Less Main Counterweight, Boxes, Beams, Floats, and Boom Point Section 3	F	*	*	*
	R	83,625 Lbs. (37932kg.)	162,330 Lbs. (73633kg.)	245,955 Lbs. (111565kg.)
Machine Less Main Counterweight, Boxes, Beams, Floats, and Complete Boom 3	F	*	*	*
	R	101,960 Lbs. (46249kg.)	123,090 Lbs. (55834kg.)	225,050 Lbs. (102083kg.)

F — Denotes Boom Extended Forward.

R — Denotes Boom Extended Rearward.

\* — Do not travel with this combination and boom location.

Tire Pressure to be 95 P.S.I. (65.5 NPScrn)

For best results, the tire manufacturers recommend the following maximum speeds with the loading shown:

1 2.5 M.P.H. (4.02 KmPH); 2 10 M.P.H. (16.10 KmPH); 3 15 M.P.H. (24.14 KmPH) 4 20 M.P.H. (32.18 KmPH)

Complete Carrier Equipped As Follows: Carrier, Outrigger Boxes, Outriggers, and Floats.

Weight Combinations	Front Bogie	Rear Bogie	Total
Complete Carrier	120,220 Lbs. (54532kg.)	40,320 Lbs. (18289kg.)	160,540 Lbs. (72821kg.)
Carrier Less Outriggers and Floats	51,140 Lbs. (23197kg.)	74,600 Lbs. (33839kg.)	125,740 Lbs. (57036kg.)
Carrier Less Outriggers, Floats, and Outrigger Boxes	49,855 Lbs. (22614kg.)	57,415 Lbs. (26043kg.)	107,270 Lbs. (48658kg.)

Tire Pressure to be 70 P.S.I. (48.3 NPScrn)

The manufacturers recommend not over 50 miles (80.5 Km) be traveled in any 1½ hour period.

## POWER PLANT DATA (CARRIER)

Make	Model	Fuel	Cyl.	Bore & Stroke	Net Horsepower
Cummins	KTA-600	Diesel	6	6¼" x 6¼" (159mm x 159mm)	525 @ 2100 R.P.M.

## PERFORMANCE DATA (CARRIER)

Truck Travel Speed — 43 M.P.H. (69.19 KmPH) on 0% grade.

equipped basic machine can travel up a 21% grade.

Basic machine less counterweight, outrigger boxes, beams, floats, and boom can travel up a 24% grade

Turning radius — 59 ft. (18m) (curb radius).

Number of travel speeds — 18 forward and 3 reverse

Tires — 16.00 x 25 (40.6cm x 63.5cm) (24 ply)

**DESCRIPTIVE DATA (CARRIER)****Basic, Standard and Optional Components**

**FRAME:** Carrier frame of heavy-duty, all welded construction. Two main members, each of deep box and I-beam section, are joined together by bumper and box section cross members. 100,000 P S I. (68944 N/cm<sup>2</sup>) steel is used in highly stressed members of Frame.

**OUTRIGGER BOXES:** The two outrigger boxes are fabricated from steel plates. Boxes are of the pin-on design for ease of removal, and are equipped with rollers for ease in rolling out outrigger beams.

**OUTRIGGER BEAMS:** Four box section extensible beams mounted two in each outrigger box are fabricated of alloy steel and equipped with hydraulic operated screw jacks and floats. Independent control valves for extending each beam and for lowering each hydraulic jack provide precise leveling of truck. Control valve station is portable for unobstructed viewing of jacks.

**FRONT TRIDEM SUSPENSION:** Front tridem axles are suspended by six alloy steel underslung equalizers, four of which are direct-connected to chassis frame. Two torque rods on each axle maintain proper positioning of axles.

**FRONT AXLES:** Three tubular-high clearance type. Wheels are mounted on roller bearings.

**REAR AXLES:** Three planetary rear drive axles, gear ratio of 11.455:1. Mid-axle has interaxle differential with lockout.

**REAR TRIDEM SUSPENSION:** Rear tridem axles are suspended by six alloy steel underslung equalizers, four of which are direct-connected to chassis frame. One torque rod on each axle maintains proper positioning of axles.

**WHEELS:** Heavy-duty 11.25 x 25 (28.6 cm x 63.5 cm) STND rims, six singles in front, six duals in rear, making a total of eighteen wheels.

**TIRES:** Eighteen 16.00 x 25 (40.6 cm x 63.5 cm) — 24 ply rating.

**FUEL CAPACITY:** 100 gallons (378 Liters)

**FENDERS:** Fenders are of the combination fender-deck design, providing a flat full width, full length walkway.

**SERVICE BRAKES:** Air brakes on all wheels. Front brake shoes are 20 1/4" (51.4cm) diameter x 5" (12.7cm) wide. Rear brake shoes are 20 1/4" (51.4cm) diameter x 7" (17.8cm) wide.

**AUXILIARY BRAKES:** Spring set, air released brake cylinders on rear axles lock brakes in case of air loss. Emergency release valve on dash allows some maneuvering after air loss. Auxiliary valve sets brakes for parking.

**OPERATING BRAKE:** A hand-operated air valve applies the service brakes when required for holding the machine when operating.

**STEERING:** Power assisted steering, with individual double acting cylinders on each front axle. The cylinders are powered by an engine driven hydraulic pump and metered by a control valve built into the draglink.

**MAIN TRANSMISSION:** Allison #5960 CLBT six speeds forward and one reverse. Transmission is equipped with TC 690 converter and hydraulic retarder.

**AUXILIARY TRANSMISSION:** Spicer P1241-C with 3 speeds giving the carrier 18 speeds forward and 3 reverse.

**CAB:** One-man type, with visor type top. All steel construction, amply ventilated for summer or winter. Adjustable seat. Instrument panel contains speedometer, odometer, ammeter, oil pressure gauge, water temperature gauge, fuel gauge and pilot lights, air gauge, converter oil temperature gauge, light switches, ignition and starter switch.

**BUMPER COUNTERWEIGHT:** One piece, required when using long boom or boom and jib combination. See "boom and jib data."

**MISCELLANEOUS ACCESSORIES:** Inflating hose and tire pressure gauge, mast rest, rear view mirrors, two beam headlights, stop and tail light, front, middle and rear marker lights and parking lights, electric directional signals, electric windshield wipers, electric dual horn, fender flaps, heater and defrosters.

**POWER PLANT DATA (ROTATOR)**

Make	Model	Fuel	Cyl.	Bore & Stroke	Net Horsepower
Cummins	NTA 855C420	Diesel	6	5 1/2" x 6" (13.97cm x 15.24cm)	420 @ 2300

**CLUTCH AND BRAKE DATA**

Function	CLUTCHES				BRAKES			
	Type	Width	Diameter	Area	Type	Width	Diameter	Area
Main Hoist	Band	4 1/2" (11.43cm)	43" (109.2cm)	518 In <sup>2</sup> (3342cm <sup>2</sup> )	Band	6" (15.24cm)	50" (127cm)	748 In <sup>2</sup> (4826cm <sup>2</sup> )
Auxiliary Hoist	Band	4 1/2" (11.43cm)	43" (109.2cm)	518 In <sup>2</sup> (3342cm <sup>2</sup> )	Band	6" (15.24cm)	50" (127cm)	748 In <sup>2</sup> (4826cm <sup>2</sup> )
Boom Hoist	Band	—	—	—	Band	4" (101.6cm)	15" (38.1cm)	145 In <sup>2</sup> (935cm <sup>2</sup> )
Swing Brake	Band	—	—	—	Band	4" (10.16cm)	26" (66cm)	258 In <sup>2</sup> (1665cm <sup>2</sup> )
Third Drum	Band	4 1/2" (11.43cm)	43" (109.2cm)	518 In <sup>2</sup> (3342cm <sup>2</sup> )	Band	6" (15.24cm)	50" (127cm)	748 In <sup>2</sup> (4826cm <sup>2</sup> )

**LAGGING DATA**

Lagging Location	Use	Drum P.D.	Drum Width	Type	Eff. Capy. 1st Layer	Maximum Capy. Layers	Wire Rope Size
Boom Hoist Shaft	Boom Hoist	15" (38.1cm)	14-7/16" (36.7cm)	Grooved	90' (27.4M)	1002' (305.4M) in 7	1" (25.4mm)
Rear Hoist Shaft	Main Hoist	24" (61cm)	38" (96.5cm)	Grooved	191' (58.2m)	1,796' (547.4M) in 7	1-1/8" (28.6mm)
Right Hand Front Hoist Shaft	Auxiliary Hoist	24" (61cm)	17 1/2" (44.5cm)	Grooved	79' (24.1M)	658' (200.6M) in 6	1-1/8" (28.6mm)
Left Hand Front Hoist Shaft	Third Drum	24" (61cm)	17 1/2" (44.5cm)	Grooved	79' (24.1M)	658' (200.6m) in 6	1-1/8" (28.6mm)
Front Hoist Shaft	Full Width Front Drum	24" (61cm)	38" (96.5cm)	Grooved	191' (58.2M)	1,796' (547.4M) in 7	1-1/8" (28.6mm)

**MISCELLANEOUS DATA (ROTATOR)**

Swing Speed	2.1 R.P.M.
Fuel Capacity	200 Ga. (757 Liters)

**DESCRIPTIVE DATA (ROTATING ASSEMBLY)****Basic, Standard and Optional Components**

**ROTATING BASE:** Fabricated with integral machine frames using alloy steel for strong, lightweight construction. Separate fuel tank.

**SHAFTING:** All shafting made from heat treated alloy steel. Involute splines used extensively.

**SWING:** Separate gear box provides power for swing. This assembly easily removed for service. Driven by hydraulic motor controlled by special fine-metering valve for precise swing control. Vertical swing shaft and pinion is one piece forging. Gearing runs in oil.

**SWING BRAKE:** A band brake at top of swing assembly is spring set, air release controllable by the operator. Also a swing snub operates this band brake for momentarily holding while setting loads.

**SWING LOCK:** A pawl engages in slots at the bottom of the swing brake housing and can be used as a upper unit parking lock.

**FRONT DRUM SHAFT:** Supported by self-aligning anti-friction bearings. Can have either two drums or a full width single drum. All drums are mounted on anti-friction bearings.

**REAR DRUM SHAFT:** Supported by self-aligning anti-friction bearings. A full width single drum for maximum rope capacity is mounted on anti-friction bearings.

**HOIST CLUTCHES:** Air actuated — internal expanding friction band type.

**HOIST BRAKES:** External contracting friction band type. Spring set — air release parking feature with an air actuated, foot pedal applied, operating brake. Separate brakes for each drum.

**HOIST DRUM RATCHET:** Each drum has a spring set, air release ratchet that's controllable by the operator.

**HOIST POWER:** Full hydraulic — hydraulic motor powers a selectable transmission to give two speed ranges, which in turn, thru a gear train, powers both front and rear drum shafts. The hydraulic motor is controlled by varying the flow of oil from the hoist pump which give infinite speed control in both raising and lowering directions. This provides Power Load Lowering on all drums with the same speed and precision as raising a load. Gearing runs in oil.

**BOOM HOIST:** Is a self-contained unit that pins to the rotating base. Two hydraulic motors, through a gear reduction, drive two drums keyed to a common shaft. Two external contracting friction band brakes are spring set — air release type that release automatically when powering up or down and set automatically when boom hoisting operation stops. The hydraulic motors are controlled by varying the flow from the boom hoist pump. This gives infinite speed control both raising and lowering the boom.

**BOOM HOIST RATCHET:** Ratchet on the drum shaft is spring set — air release and controllable by the operator.

**BOOMS AND JIBS:** Extensible type with tubular T1 chords — refer to boom and jib data.

**BOOM STOP:** Telescopic with automatic air cut-off of boom hoisting power. Stops are attached to the boom base or to the mast when using it as a boom.

**BOOM SUSPENSION:** 14-part line from gantry to mast. Slings from mast to boom point with mid-point suspension when boom length dictates.

**COUNTERWEIGHT:** Three piece — cast iron hooked on at rear of rotating frame. Readily removable for weight reduction.

**COUNTERWEIGHT REMOVAL EQUIPMENT:** Using links and gantry hydraulic cylinders, the counterweights can be removed or added in two sections rapidly and smoothly.

**GANTRY:** Back hitch type with the rear legs made up of two hydraulic cylinders and telescopic sections. Can be pinned up at maximum height for working and pinned down at cab height for traveling.

**MACHINERY CAB:** Steel construction with doors and hatches conveniently located for easy service of engine and machinery. All doors can be latched open or closed. Louvers are adjustable to provide proper heating or cooling to engine and hydraulic components.

**OPERATOR'S POD:** Swings in for shipping — nothing has to be disconnected or removed — and swings out for working. Hydraulically controlled from operator's seat or from ground. All steel construction, full 360° vision with rubber-set windows. Front and right hand windows can be opened. Can be heated, air conditioned, and is sound conditioned for operator's comfort.

**SWING CIRCLE:** Upper rotating unit mounts on a roller bearing swing circle that has internal cut teeth which mate with the swing pinion. Circulating oil lubricates the gear teeth. The inner half of the swing circle mounts to the truck by extended tangs that fit into slots in the truck. Adjustable wedges lock these tangs in place, affording easy and rapid removal of the upper from the truck.

**GEARING:** Note — All gears are fully enclosed and run in oil.

**POWER TAKE-OFF:** Engine driven pump drive gear box that has a master clutch disconnect. Each function, swing, boom hoist, hoist, and propel (for crawler version) has a separate pump for independent control.

**HYDRAULIC SYSTEM:** Steel tubing and hose connect the pumps and motors. The tank is equipped with filters, strainers, and level indicator. An oil cooler is mounted in front of the engine radiator.

**OPTIONAL INDEPENDENT DRIVE FRONT DRUM:** This has a separate hydraulic pump and motor to power the front drum with all the control features of the rear drum power. This offers more versatility to the hoisting function.

MAXIMUM BOOM OR BOOM PLUS JIB THAT CAN BE HANDLED HORIZONTALLY			
OVER REAR ON STANDARD AND REAR AUXILIARY OUTRIGGERS		OVER SIDE ON STANDARD OUTRIGGERS	
Less Bumper Counterweight	With Bumper Counterweight	Less Bumper Counterweight	With Bumper Counterweight
330' (100.58M)	330' (100.58M)	300' (91.44M)	310' (94.49M)
310' (94.49M) + 40' (12.19M)	330' (100.58M) + 40' (12.19M)	270' (82.30M) + 40' (12.19M)	270' (82.30M) + 40' (12.19M)
300' (91.44M) + 50' (15.24M)	330' (100.58M) + 50' (15.24M)	240' (73.15M) + 50' (15.24M)	240' (73.15M) + 50' (15.24M)
290' (88.39M) + 60' (18.29M)	320' (97.54M) + 60' (18.29M)	240' (73.15M) + 60' (18.29M)	240' (73.15M) + 60' (18.29M)
290' (88.39M) + 70' (21.34M)	320' (97.54M) + 70' (21.34M)	240' (73.15M) + 70' (21.34M)	240' (73.15M) + 70' (21.34M)
290' (88.39M) + 80' (24.38M)	310' (94.49M) + 80' (24.38M)	230' (70.10M) + 80' (24.38M)	230' (70.10M) + 80' (24.38M)
280' (85.34M) + 90' (27.43M)	310' (94.49M) + 90' (27.43M)	210' (70.10M) + 90' (27.43M)	210' (70.10M) + 90' (27.43M)
280' (85.34M) + 100' (30.48M)	310' (94.49M) + 100' (30.48M)	220' (67.06M) + 100' (30.48M)	220' (67.06M) + 100' (30.48M)

OVER REAR ON STANDARD OUTRIGGERS		OVER SIDE WITH AUXILIARY AND STANDARD OUTRIGGERS
Less Bumper Counterweight	With Bumper Counterweight	With Bumper Counterweight
330' (100.58M)	330' (100.58M)	320' (97.54M)
280' (85.34M) + 40' (12.19M)	310' (94.49M) + 40' (12.19M)	280' (85.34M) + 40' (12.19M)
270' (82.30M) + 50' (15.24M)	300' (91.44M) + 50' (15.24M)	280' (85.34M) + 50' (15.24M)
270' (82.30M) + 60' (18.29M)	300' (91.44M) + 60' (18.29M)	270' (82.30M) + 60' (18.29M)
270' (82.30M) + 70' (21.34M)	290' (88.39M) + 70' (21.34M)	270' (82.30M) + 70' (21.34M)
240' (73.15M) + 80' (24.38M)	290' (88.39M) + 80' (24.38M)	270' (82.30M) + 80' (24.38M)
240' (73.15M) + 90' (27.43M)	280' (85.34M) + 90' (27.43M)	250' (76.20M) + 90' (27.43M)
240' (73.15M) + 100' (30.48M)	280' (85.34M) + 100' (30.48M)	240' (73.15M) + 100' (30.48M)

## BOOM DATA

Component	Light Duty Boom	Heavy Duty Boom
Point Shaft	1,100 Lbs. ( 499kg.)	2,600 Lbs. (1179kg.)
30' (13.61M) Point Section	5,160 Lbs. (2341kg.)	6,890 Lbs. (3125kg.)
40' (12.19M)	7,725 Lbs. (3504kg.)	7,725 Lbs. (3504kg.)
Basic Pendants Base Section	800 Lbs. ( 363kg.)	970 Lbs. ( 440kg.)
10' (3.05M) Extension With Pendants	1,825 Lbs. ( 828kg.)	1,895 Lbs. ( 860kg.)
20' (6.10M) Extension With Pendants	2,900 Lbs. (1315kg.)	2,975 Lbs. (1349kg.)
40' (12.19M) Extension With Pendants	4,995 Lbs. (2266kg.)	5,095 Lbs. (2311kg.)
40' (12.19M) Mast	8,275 Lbs. (3754kg.)	8,275 Lbs. (3754kg.)
Boom Stop	1,365 Lbs. ( 619kg.)	1,365 Lbs. ( 619kg.)
Midpoint Suspension 170' (51.82M) Boom to 230' (70.10M) Boom	1,050 Lbs. ( 476kg.)	1,050 Lbs. ( 476kg.)
Midpoint Suspension 240' (73.15M) Boom to 260' (79.25M) Boom	1,190 Lbs. ( 540kg.)	1,190 Lbs. ( 540kg.)
Midpoint Suspension 270' (82.30M) Boom and 330' (100.53M) Boom	1,420 Lbs. ( 644kg.)	1,420 Lbs. ( 644kg.)
Boom Hoist Wire Rope	2,460 Lbs. (1116kg.)	2,460 lbs. (1116kg.)
Main Hoist Wire Rope	3,750 Lbs. (1702kg.)	3,750 Lbs. (1702kg.)
Auxiliary Hoist Wire Rope	2.46 Lbs./Ft. (3.66kg./M)	2.46 Lbs./Ft. (3.66kg./M)
300 Ton Hookblock	5,400 Lbs. (2449kg.)	5,400 Lbs. (2449kg.)
40 Ton Hookblock	1,100 Lbs. ( 499kg.)	1,100 Lbs. ( 499kg.)
20 Ton Ball and Hook	800 Lbs. ( 363kg.)	800 Lbs. ( 363kg.)

Boom Make-up: The first 70' (21.34M) of boom extensions adjacent to the boom base must be 6" (152mm) O.D. tubing; all remaining extensions should be 5 1/4" (146mm) O.D. tube. The heavy duty boom point section with heavy duty point shaft is to be installed on booms 70' (21.34M) thru 250' (76.20M); the light duty boom point with light duty point shaft is to be installed on booms 260' (79.25M) thru 330' (100.58M)

 **JIB DATA**

Component	Heavy Duty Jib
Basic Jib Length	40' (12.19M)
Maximum Length	100' (30.48M)
Basic Jib	5,040 Lbs. (2286kg.)
10' (3.05M) Extension With Pendant	660 Lbs. ( 299kg.)
20' (6.10M) Extension with Pendant	1,005 Lbs. ( 456kg.)

 **BOOM AND JIB DATA**

JIB	
Basic Length	40' (12.19M)
Max. Length	100' (30.48M)
Section	46" x 52" (1.7M x 1.32M)
Chord Size	2 1/2" (6.35cm) O.D. Tube
Chord Material	100,000 P.S.I. (68944 N/cm <sup>2</sup> )
Quan. Sheaves at Point	One (1)
P.D. Point Sheave	21-3/8" (54.3cm) P.D.
Capacity	
40' (12.19M)	40 Tons (36.3 Tons)
50' (15.24M)	3 1/2 Tons (28.6 Tons)
60' (18.29M)	24 Tons (21.8 Tons)
70' (21.34M)	20 Tons (18.1 Tons)
80' (24.38M)	18 Tons (16.3 Tons)
90' (27.43M)	15 1/2 Tons (14.1 Tons)
100' (30.48M)	13 1/2 Tons (12.2 Tons)

BOOM, TUBULAR PIN CONNECTED		
Type Service	Crane	
Suspension	Mast and Pendants	
Gantry	High Back Hitch	
Mast	40' (12.19M)	
Quan. Sheaves at Point Shaft	Light Duty Point	3
	Heavy Duty Point	7
Dia. Point Sheaves	21-3/8" (54.3cm) P.D. — 1-1/8" (29mm) Dia. Wire Rope	
Basic Boom Length	70' (21.34M)	
Chord Material	100,000 P.S.I. (68944 N/cm <sup>2</sup> ) Steel	
Extensions	10', 20', and 40' Straight (3.05M, 6.10M, and 12.19M)	
Section	90" x 108" (2.29M x 2.74M)	
Max. Boom Length	330' (100.58M)	
Chord Dimensions	Light Duty	5-3/4" O.D. (146mm) Tube
	Heavy Duty	6" O.D. (152mm) Tube

# HOIST LINE DATA

Typical Hoist Performance Both Front & Rear Hoist Shafts		
Speed Range	Line Pull	Line Speed
1st	40,000 Lbs. (18144kg.)	180 F.P.M. (54.86M.P.M.)
2nd	20,000 Lbs. (9072kg.)	350 F.P.M. (106.68M.P.M.)

Optional Independent Front Drive Hoist	
Typical Hoist Performance Front Hoist Only	
Line Pull	Line Speed
25,000 Lbs. (11340kg.)	185 F.P.M. (56.39 M.P.M.)

